

CDD15J-ZSM

Electric pallet stacker

Characteristics:

- AC drive; carbon-brush free and maintenance free.
- ZF transmission box has superior performance, high working and energy efficiency.
- The truck adopts side operation mode and has small turning radius and wide view.
- Imported waterproof inching switch is suitable for harsh application such as cold, humid and dust environment.
- LED electricity meter with four color is easy for reading.
- External placed charger has better cooling performance.
- Over length operation handle integrating lifting buttons, key switch and electricity meter satisfy ergonomic requirements and make operation easier; low speed switch makes speed control more accurate; good air pressure type can reset automatically and slowly and it is durable.
- High-density protection guard is solid and durable.



CDD15J-ZSM

制造商和技术参数 Manufacturer's Data and Design Characteristics

Characteristics			
1.1	Manufacturer	HELI	
1.2	Model	CDD15J-ZSM	
1.3	Operator type	Pedestrian propelled	
1.4	Rated capacity	Q (kg)	1500
1.5	Mast type	3-Stage STD	
1.6	Lift height	h3 (mm)	4000
1.7	Capacity at highest height	kg	700
1.8	Service weight with battery	kg	1126
1.9	Load centre	c (mm)	600
1.10	Axle centre to fork face	x (mm)	672
1.11	Wheel base	y (mm)	1384
1.12	Controller	CURTIS	
Wheels			
2.1	Tyre type	Polyurethane	
2.2	Tyre size, Driving wheel	Φ × w (mm)	Φ230 × 75
2.3	Bearing wheel size	Φ × w (mm)	Φ80 × 70
2.4	Additional wheels (dimensions)	Φ × w (mm)	Φ150 × 58
2.5	Wheels, number front/rear (x=driven)	1x+1/4	
Dimensions			
3.1	Height of mast, lowered	h1 (mm)	1900
3.2	Free lifting height	h2 (mm)	1486
3.3	Height of mast, extended	h4 (mm)	4424
3.4	Lowered height	h13 (mm)	86
3.5	Overall length	l1 (mm)	2022
3.6	Length to fork face	l2 (mm)	872
3.7	Overall width	b1/ b2 (mm)	795
3.8	Fork dimensions	s/e/l (mm)	60/180/1150
3.9	Width of forks	b5 (mm)	570/650/695
3.10	Min. Ground clearance	m2 (mm)	26
3.11	Aisle width with pallet 1000 x 1200 across forks	Ast (mm)	2435
3.12	Aisle width with pallet 800 x 1200 along forks	Ast (mm)	2412
3.13	Min. Turning radius	Wa (mm)	1550
Performance			
4.1	Travel speeds, with/without load	(km/h)	4.0/4.2
4.2	Lifting speed, with/without load	(mm/s)	80/210
4.3	Lowering speed, with/without load	(mm/s)	152/160
4.4	Max. gradeability laden/unladen	(%)	6/8
4.5	Service brake type	Electromagnetic brake	
Drive and Battery			
5.1	Drive motor, output S2 60 min.	(kW)	1.5 (AC)
5.2	Lift motor rating at S3 15%	(kW)	3.0
5.3	Battery according to DIN 43531/35/36 A,B,C, no		no
5.4	Battery voltage/rated capacity	(V/Ah)	24/210
5.5	Battery weight (± 5%)	(kg)	195
Others			
6.1	Sound pressure level at driver's ear	(dB(A))	≤ 70
6.2	Steering type	Mechanical steering	

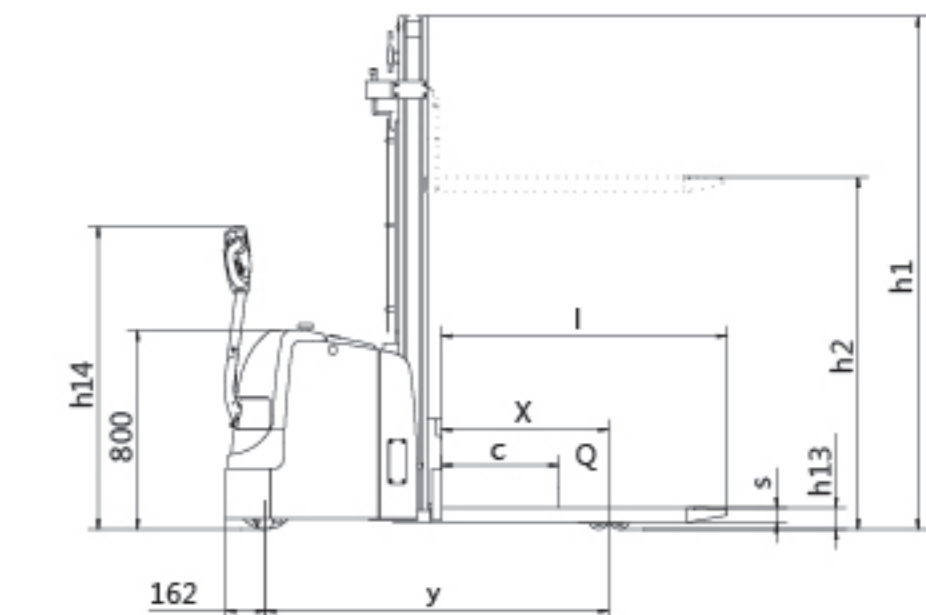
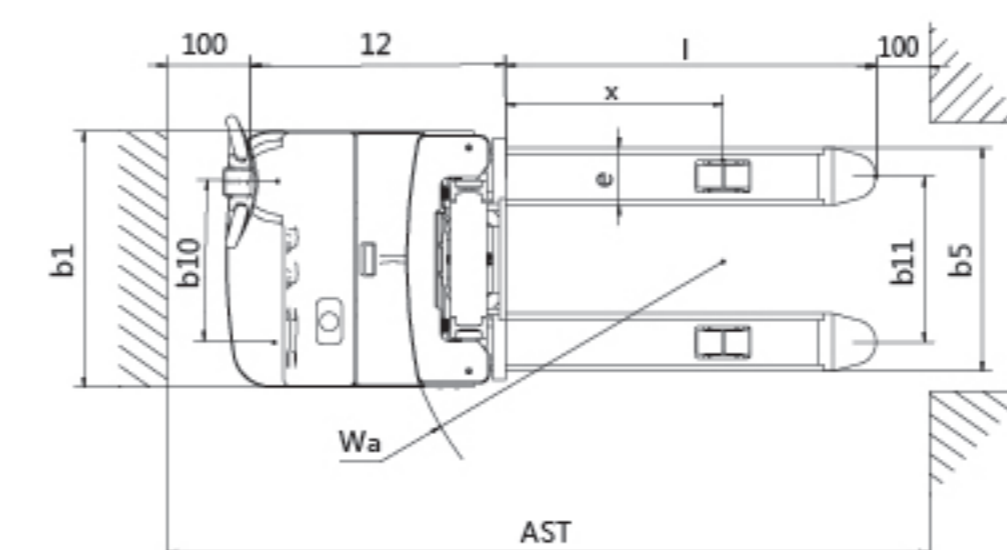

ANHUI HELI CO., LTD.

Add / No.668, FangXing Street, Hefei, P.R. China
Post Code / 230000

Customer Service Hotline / 4001-600761

Service Tel / +86-511-63639068, 63639258, 63639358