

CDD12/14

1.2-1.4 Ton Electric Stacker

Lifting Height: 1400-4000mm

Load Curve

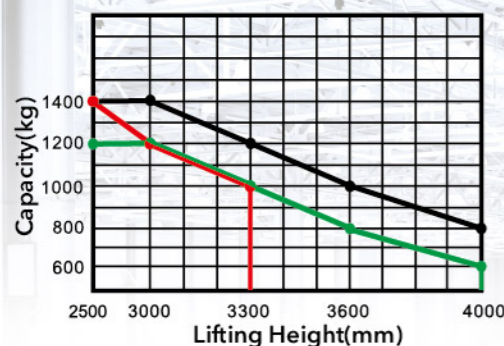

- CDD12-030
- CDD14-930
- CDD14-980



Advantages

Configuration and Performance

- Electronic power steering system, light and low noise.
- Two-way magnetic valve, three drop speed mode.
- Drive unit floating bodies with patent design.
- AC Driving system, No carbon brush, maintenance free.
- Electromagnetic, regenerative braking system.
- Automatic lifting limit, proximity switch, long life.

Safety

- Curve automatic deceleration devices, more safe.
- Vehicle decelerates automatically at higher position.
- Stepless speed control system, safe and quiet.
- Controller with Multiple automatic protection.
- Emergency reversing device/Emergency brake switch.
- High position automatic reduction device.

AC | EPS

Down mode at 3 speeds

Steering automatic deceleration

Truck automatically decelerates while at higher lifting position

Fork-over typed stacker

Type	Lift height (mm)	Mast type	Outside width between legs (mm)	Inside width between legs (mm)
CDD12-030	2000/2500/3000/3300/3600/4000	Standard 2-STAGE	550/600/650/685	180/230/280/315
CDD14-930	1400/2000/2500/3000/3300/3600/4000	Standard 2-STAGE	550/600/650/685	180/230/280/315
CDD14-980	2500/3000/3300	FULL FREE 2-STAGE	550/600/650/685	180/230/280/315

HELI CDD12/14

Feature				
Model		CDD12-030	CDD14-930	CDD14-980
Type		Fork over	Fork over	Fork over
Mast type		Standard 2-Stage	Standard 2-Stage	Full free 2-Stage
Load capacity	kg	1200	1400	1400
Load center	mm	600	600	600
Wheel base	mm	1270	1325	1325
Operating type		Walkie/Stand On		
Wheels				
Wheels type		PU	PU	PU
Wheel quantity Driving wheel/ Balance wheel/Bearing wheel		1/2/4	1/2/4	1/2/4
Dimension				
Standard lift height	mm	2000/2500/3000/3300/3600/4000	1400/2000/2500/3000/3300/3600/4000	2500/3000/3300
Lowered fork height	mm	90	90	90
Fork size(length/width/thickness)	mm	1150(1220)/185/55	1150(1220)/185/55	1150(1220)/185/55
Overall length	mm	1993/2413	2050/2470	2050/2470
Overall width	mm	812	856	856
Max.extend height	mm	2500/3000/3500/3800/4100/4500	1900/2500/3000/3500/3800/4100/4500	3000/3500/3800
Mast lowered height	mm	1535/1765/1980/2135/2335/2500	1185/1535/1765/1980/2135/2335/2500	1830/2080/2180
Min.Turning radius	mm	1525/1935	1580/1990	1580/1990
Min.Aisle width for pallets 800×1200	mm	2130/2520	2180/2580	2180/2580
Min.Aisle width for pallets 1000×1200	mm	2160/2540	2210/2600	2210/2600
Min.ground clearance	mm	30	30	30
Performance				
Travel speed,laden/unladen	km/h	6/6	6/6	6/6
Lift speed,laden/unladen	mm/s	130/180	130/180	130/180
Lowering speed,laden/unladen	mm/s	100/200	100/200	100/120
Gradeability,laden/unladen	%	6/8	6/8	6/8
Electrical configuration				
Drive motor/Lift motor/Steering motor	kW	AC1.5/DC3/DC0.15	AC1.5/DC3/DC0.15	AC1.5/DC3/DC0.15
Battery voltage	V	24	24	24
Battery capacity	Ah	210	280	280
Brake		Electromagnetic/Regenerative		
Controller		ZAPI (Option CURTIS)		
Weight				
Battery weight	kg	192	235	235
Service weight with battery	kg	1076	1158	1206

* Details of specifications and equipment are based on information available at time of printing and may change without notice.

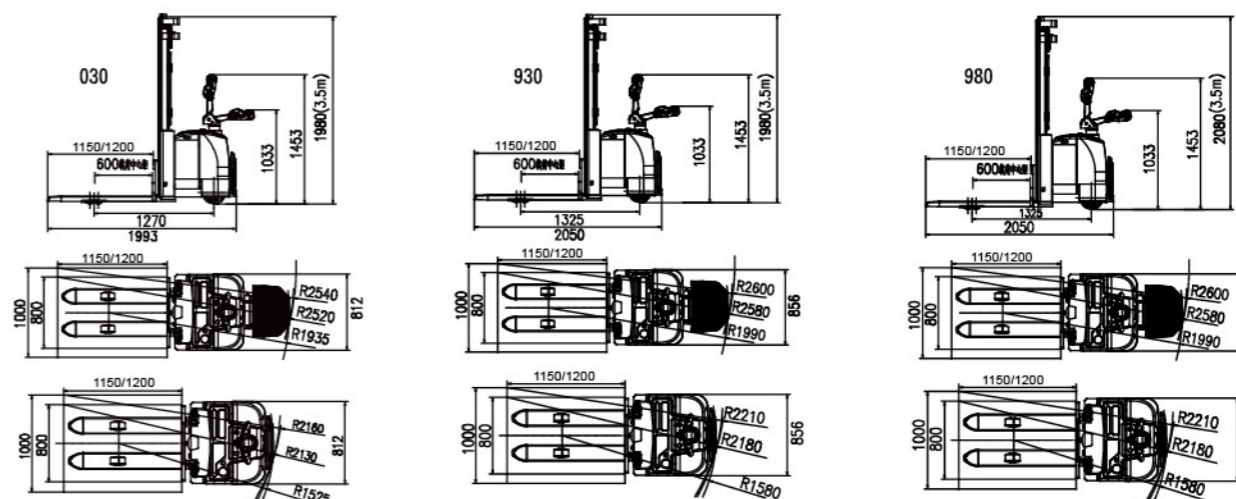

ANHUI HELI CO., LTD.

ADD: NO.668 Fangxing Street, Economical Development Zone, Hefei, P.R.China
 TEL: (86 551)63639068 (America) 63639258 (Europe) 63639358 (Asia)
 63662105 (Africa & Middle East) 63639530 (Key Accounts division)
 63662105 (Wheel loader)
 FAX: (86 551)63639966
 WEBSITE: <http://www.heliforklift.net>
 Email: heli@helichina.net

AUTHORIZED DEALER