

## CDD16

### Forkover Electric Stacker

Lifting Height: 1400-5800mm

#### Load Curve

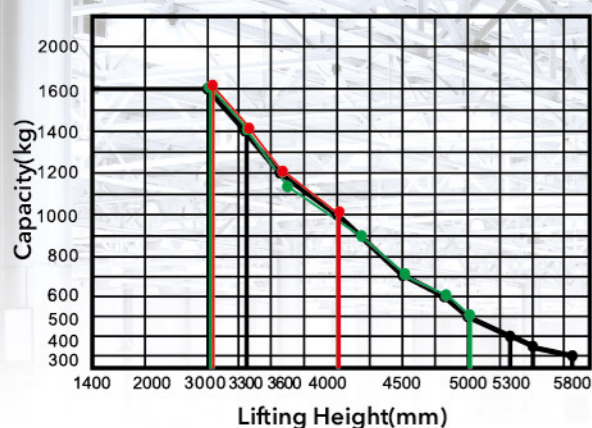

- CDD16-950
- CDD16-D930
- CDD16-350



#### Advantages

##### Configuration and Performance

- Electronic power steering system, light and low noise.
- Two-way magnetic valve, three drop speed mode.
- Drive unit floating bodies with patent design.
- AC Driving system, No carbon brush, free maintenance.
- USA CURTIS driving controller.
- Electromagnetic, regenerative braking system.
- Automatic lifting limit, proximity switch, long life.

##### Safety

- Curve automatic deceleration devices, more safe.
- Vehicle decelerates automatically at higher position.
- Stepless speed control system, safe and quiet.
- Controller with Multiple automatic protection.
- Emergency reversing device/Emergency brake switch.
- High position automatic reduction device.

AC | EPS

Down mode at 3 speeds

Steering automatic deceleration

Truck automatically decelerates while at higher lifting position

Type	Lift height (mm)	Mast type	Outside width between legs (mm)	Inside width between legs (mm)
CDD16-D930	1400/2000/2500/3000/3300/3600/4000	Standard 2-STAGE	550/600/650/685	180/230/280/315
CDD16-950	3700/3900/4200/4500/4700/5000	FULL FREE 3-STAGE		
CDD16-350	5300/5500/5800	FULL FREE 3-STAGE		

Feature		CDD16	CDD16	CDD16
Model		CDD16	CDD16	CDD16
Configuration No.		D930	950	350
Type		Narrow legs	Narrow legs	Narrow legs
Mast type		Standard 2-Stage	Full free 3-Stage	Full free 3-Stage
Load capacity	kg	1600	1600	1600
Load center	mm	600	600	600
Wheel base	mm	1325	1375	1375
Operating type		Walkie/Stand On		
<b>Wheels</b>				
Wheels type		PU	PU	PU
Wheel quantity Driving wheel/Balance wheel/Bearing wheel		1/2/4	1/2/4	1/2/4
<b>Dimension</b>				
Standard lift height	mm	1400/2000/2500/3000/3300/3600/4000	3700/3900/4200/4500/4700/5000	5300/5500/5800
Lowered fork height	mm	90	90	90
Fork size(length/width/thickness)	mm	1150(1220)/185/55	1150(1220)/185/55	1150(1220)/185/55
Overall length	mm	2050/2470	2105/2525	2105/2525
Overall width	mm	856	957	957
Max.extend height	mm	1900/2500/3000/3500/3800/4100/4500	4200/4400/4700/5000/5200/5500	5800/6000/6300
Mast lowered height	mm	1185/1535/1765/1980/2135/2335/2500	1800/1900/1985/2085/2135/2235	2520/2590/2690
Min.Turning radius	mm	1580/1990	1595/2010	1595/2010
Min.Aisle width for pallets 800×1200	mm	2180/2580	2230/2625	2230/2625
Min.Aisle width for pallets 1000×1200	mm	2210/2600	2260/2650	2260/2650
Min.ground clearance	mm	30	30	30
<b>Performance</b>				
Travel speed,laden/unladen	km/h	6/6	6/6	6/6
Lift speed,laden/unladen	mm/s	130/180	130/180	130/180
Lowering speed,laden/unladen	mm/s	100/230	100/160	100/160
Gradeability,laden/unladen	%	6/8	6/8	6/8
<b>Electrical configuration</b>				
Drive motor/Lift motor/Steering motor	kW	AC1.5/DC3/DC0.15	AC1.5/DC3/DC0.15	AC1.5/DC3/DC0.15
Battery voltage	V	24	24	24
Battery capacity	Ah	280	280	280
Brake		Electromagnetic/Regenerative		
Controller		ZAPI (Options CURTIS)		
<b>Weight</b>				
Battery weight	kg	235	235	235
Service weight with battery	kg	1213	1585	1649

\* Details of specifications and equipment are based on information available at time of printing and may change without notice.

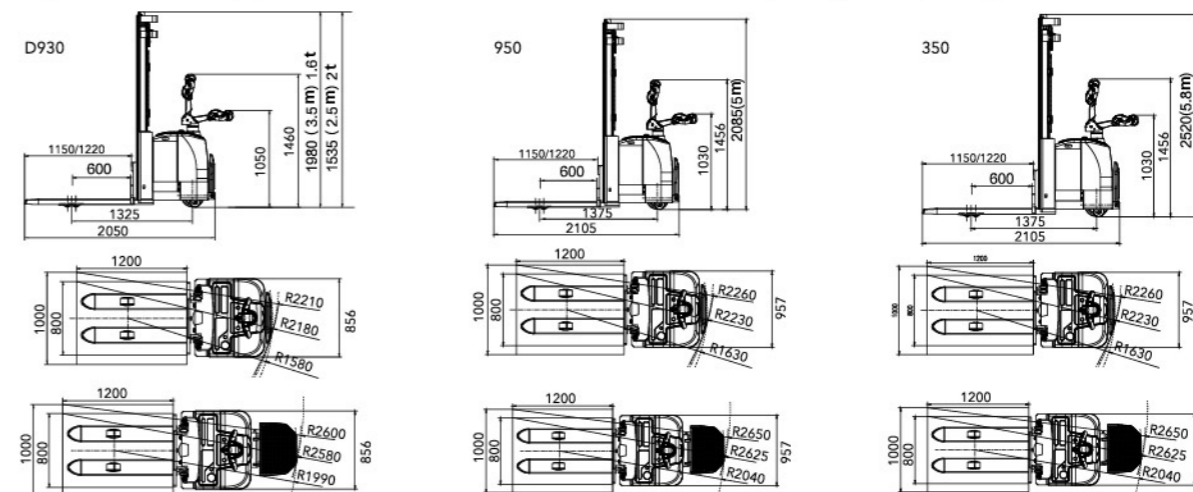

#### ANHUI HELI CO., LTD.

ADD: NO.668 Fangxing Street, Economical Development Zone, Hefei, P.R.China  
 TEL: (86 551)63639068 (America) 63639258 (Europe) 63639358 (Asia)  
 63662105 (Africa & Middle East) 63639530 (Key Accounts division)  
 63662105 (Wheel loader)  
 FAX: (86 551)63639966  
 WEBSITE: <http://www.heliforklift.net>  
 Email: [heli@helichina.net](mailto:heli@helichina.net)

AUTHORIZED DEALER