

WIDE VIEW FULL FREE 3-STAGE MAST											
Mast model	Lifting height (mm) h3		Free lifting height (mm) h2		Mast height, lowered (mm) h1		Load capacity (kg)		Total weight (kg)		Fork tilt angle (front/rear) α/β
	CQD16	CQD20	CQD16	CQD20	CQD16	CQD20	CQD16	CQD20	CQD16	CQD20	
ZSM460	4600	4600	1280	1280	2314	2314	1600	2000	3395	3560	2°/4°
ZSM480	4800	4800	1340	1340	2381	2381	1600	2000	3410	3580	2°/4°
ZSM540	5400	5400	1540	1540	2581	2581	1600	2000	3454	3640	2°/4°
ZSM570	5700	5700	1640	1640	2681	2681	1550	1900	3476	3670	2°/4°
ZSM630	6300	6300	1840	1840	2881	2881	1500	1900	3521	3730	2°/4°
ZSM675	6750	6750	1940	1940	2982	2982	1450	1800	3576	3775	2°/4°
ZSM700	7000	7000	2030	2030	3065	3065	1400	1700	3595	3800	2°/4°
ZSM715	7150	7150	2080	2080	3115	3115	1400	1700	3606	3820	2°/4°
ZSM750	7500	7500	2190	2190	3232	3232	1300	1700	3633	3850	2°/4°
ZSM800	8000	8000	2360	2360	3398	3398	1200	1500	3669	3900	2°/4°
ZSM850	8500	8500	2530	2530	3564	3564	1100	1300	3706	3950	2°/4°
ZSM900	9000	9000	2690	2690	3730	3730	900	1100	3742	4000	2°/4°
ZSM950	9500	9500	2860	2860	3898	3898	800	1000	3780	4050	2°/4°
ZSM1000	-	10000	-	3030	-	4064	-	850	-	4100	2°/4°
ZSM1050	-	10500	-	3190	-	4230	-	800	-	4150	2°/4°
ZSM1080	-	10800	-	3290	-	4330	-	750	-	4180	2°/4°
ZSM1100	-	11000	-	3360	-	4398	-	700	-	4200	2°/4°
ZSM1150	-	11500	-	3530	-	4564	-	650	-	4250	2°/4°
ZSM1200	-	12000	-	3690	-	4730	-	550	-	4300	2°/4°
ZSM1250	-	12500	-	3860	-	4898	-	500	-	4350	2°/4°

WIDE VIEW MAST											
Mast model	Lifting height (mm) h3		Free lifting height (mm) h2		Mast height, lowered (mm) h1		Load capacity (kg)		Total weight (kg)		Fork tilt angle (front/rear) α/β
	CQD16	CQD20	CQD16	CQD20	CQD16	CQD20	CQD16	CQD20	CQD16	CQD20	
M290	2900	80	2200	1600	2000	3140	3660	2°/4°			
M320	3200	80	2350	1600	2000	3150	3370	2°/4°			
M360	3600	80	2550	1600	2000	3180	3400	2°/4°			
M380	3800	80	2650	1600	2000	3200	3420	2°/4°			
M400	4000	80	2750	1600	2000	3210	3430	2°/4°			
M420	4200	80	2850	1600	2000	3230	3450	2°/4°			
M440	4400	80	2950	1600	2000	3240	3460	2°/4°			
M460	4600	80	3050	1600	2000	3300	3510	2°/4°			
M500	5000	80	3250	1500	1900	3320	3540	2°/4°			

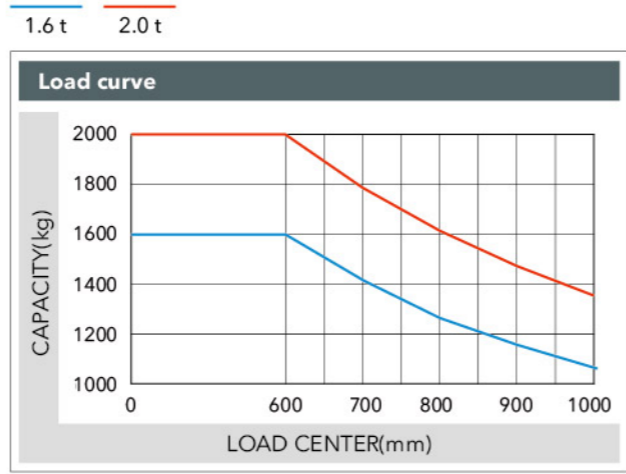
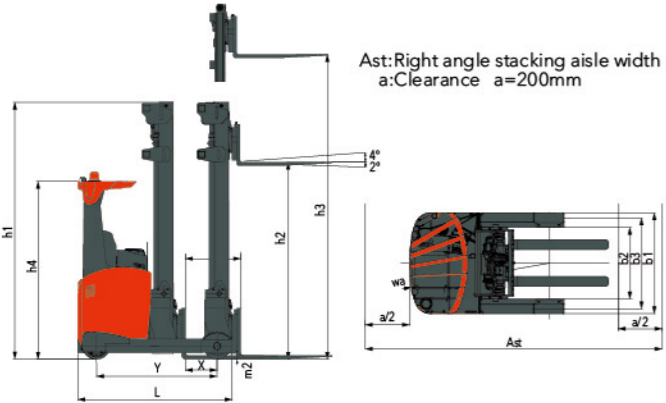

↑15%
THE PERFORMANCE OF BATTERY INCREASES

Renewable energy technologies
With the use of AC controlling renewable energy technologies, the forklift is more energy-saving and the working hour of the battery is extended by 15%.

Note: The vertical axis denotes capacity and the horizontal axis denotes load center, which is calculated from front face of fork to centre of load. Standard load is one cubic metre hence 500mm load centre. When tilting forward or using non-standard forks, the capacity will be reduced as load center is increased.

Manufacturer's Data and Design Characteristics

Character				
1.01	Manufacturer	HELI		
1.02	Model	CQD16	CQD20	
1.03	Configuration number	GB25	GB25	
1.04	Load capacity	Q kg	1600	2000
1.05	load center distance	C mm	600	
1.06	Power mode	Battery		
1.07	Driving mode	Seated		
1.08	Wheel base	Y mm	1450	1515
Tyre				
2.01	Tyre type	Polyurethane		
2.02	Wheels, number front/rear (x=driven wheels)	1x/2		
2.03	Track width, rear	b3 mm	1157	1143
2.04	Wheel size, rear	mm	φ 285x100	φ 330x100
2.05	Wheel size, front	mm	φ 343x114	φ 343x114
Size				
3.01	Lift height	h3 mm	4600	4600
3.02	Free lift	h2 mm	1280	1280
3.03	Mast height, lowered	h1 mm	2314	2314
3.04	Fork size:thickness×width×length	s/e/l mm	40x122x1150	40x122x1150
3.05	Fork adjusting width	mm	0~724	0~724
3.06	Fork tilt angle (front/rear)	α/β °	2°/4°	2°/4°
3.07	Fork sideshifting	mm	±75	±75
3.08	Truck body length (fork excluded)	L mm	1840	1942
3.09	Truck body width	b1 mm	1270	1270
3.10	Distance between support arms	b2 mm	900	900
3.11	Reach distance	L4 mm	606	620
3.12	Height of overhead guard (cab)	h4 mm	2215	2215
3.13	Ground clearance, below mast	m2 mm	75	75
3.14	Turning radius	Wa mm	1689	1751
3.15	Load distance, centre of support arm wheel to face of forks	X mm	369	383
3.16	Aisle width with pallet 1200 x 1200 across forks	Ast mm	2914	2965
3.17	Aisle width with pallet 1000 x 1200 across forks	Ast mm	2760	2810
Performance				
4.01	Travelling speed: with/without load	km/h	11/12	12/14
4.02	Lifting speed: with/without load	m/s	0.34/0.53	0.35/0.55
4.03	Lowering speed: with/without load	m/s	0.5/0.5	0.5/0.5
4.04	Reach speed, with/without load	m/s	0.11/0.11	0.11/0.11
4.05	Maximum climbing ability, with/without load	%	10/15	10/15
Weight				
5.01	Total weight (with battery)	kg	3395	3560
5.02	Axle load, fork outreached, without load, front/rear	kg	1500/1895	1590/1970
5.03	Axle load, fork retracted, without load, front/rear	kg	2013/1383	2230/1330
5.04	Axle load, fork outreached, with load, front/rear	kg	578/4415	550/5010
5.05	Axle load, fork retracted, with load, front/rear	kg	1759/3234	1960/3600
Battery				
6.01	Battery voltage/capacity Ks	V/Ah	48/450	48/560
6.02	Battery weight	kg	750	967
6.03	Battery box dimension	mm	1220x283x784	1220x352x784
Motor and controller				
7.01	Drive motor power	kW	6	8
7.02	Lifting motor power	kW	11	12.5
7.03	Steering motor power	kW	0.4	0.4
7.04	Type of driving control	MOSFET/AC		
7.05	Type of Lifting control	MOSFET/AC		
7.06	Type of Steering control	MOSFET/AC		
7.07	Transmission box	HELI special transmission box		
7.08	Service brake	Electromagnetic brake		
7.09	Hydraulic system working pressure	Mpa	17.5	20.5

NOTE: *Detailed information about battery, please contact our salesman or engineer.

HELI

The reliable special instrument gives a complete display of the vital information, like operation status, fault detection, etc. It ensures the operator predominate the vehicle status more intuitive and convenient.

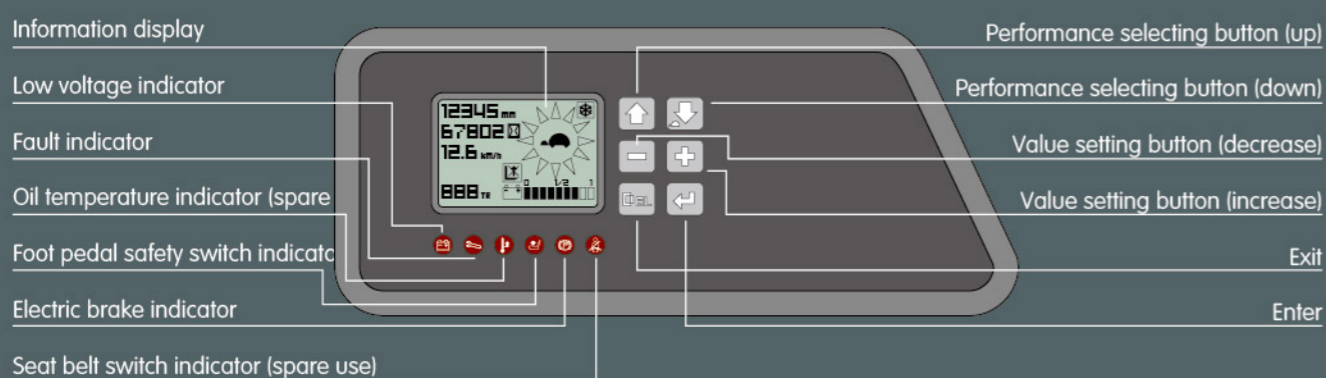

STANDARD CONFIGURATION

- AC travelling motor
- AC lifting motor
- AC steering motor
- ZAPI travelling motor controller
- ZAPI lifting motor controller
- ZAPI steering motor controller
- Electromagnetic brake
- DC/DC converter
- Low noisy gear pump
- Control valve (four throw)
- 4600mm three stage full free lift mast
- Integral sideshifter
- Standard fork
- Backrest
- Polyurethane tyre
- LED meter
- Front working light
- Warning light

OPTIONAL DEVICE

- Three-stage full free lift mast (other lifting height)
- fork with other length
- Fork extension
- Lifting height pre-selector
- Monitoring system
- Other battery
- Germany hoppecker battery
- Italy FAAM battery
- Battery charger
- Customer made color

* Details of specifications and equipment are based on information available at time of printing and may change without notice.



ANHUI HELI CO., LTD.
ADD: NO.668 Fangxing Street, Economical Development Zone, Hefei, P.R.China
TEL: (86 551)63639068 (America) 63639258 (Europe) 63639358 (Asia)
63662105 (Africa & Middle East) 63639530 (Warehouse Equipment)
63639531 (Wheel loader)
FAX: (86 551)63639966
WEBSITE: http://www.helichina.net
Email: heli@helichina.net

AUTHORIZED DEALER



HELI
LIFTING THE FUTURE

SINCE 1958

1.6-2.0t G2 series
AC Electric Reach Truck
Sit Down Type (High Efficiency)

1.6-2.0t G2 series

AC Electric Reach Truck Sit Down Type (High Efficiency)

FEATURES OF THE COMPLETED TRUCK

Three phase AC type motor technology

- > Three phase AC type motor control on travelling, lifting and steering
- > Good acceleration
- > Fast and sensitive respond on travel direction shifting Free from maintenance motor without carbon brush having long service life and low maintenance cost
- > Energy regenerating during deceleration extending operation hours
- > Max. travelling speed without load 20% increased
- > Max. travelling speed with load 27% increased

Newly designed hydraulic system

- > Newly designed hydraulic system with high working efficiency
- > High power lifting motor
- > MOSFET lifting speed governing electric controller
- > New type low noisy gear pump
- > Max. lifting speed without load 15% increased
- > Max. lifting speed with load 25% increased

G2 series / INTELLIGENT
ENVIRONMENT-FRIENDLY

Optimized intelligent design

- > ZAPI travelling motor controller
- > ZAPI lifting motor controller
- > ZAPI steering motor controller
- > CAN bus technology
- > Emergency power off of both main circuit and control circuit
- > Parking brake on slope
- > Operation sequence protection
- > Travelling speed control
- > Electric controller self protection
- > Lifting height pre-selector (optional)

Advanced EPS electric powered steering

- > EPS electric powered steering offering easy, flexible, high efficient and mute operation
- > Steering motor controller
- > Automatic centering function
- > Real-time shifting between 180°steering mode and 360° steering mode
- > Automatic limit on speed and accelerated speed when steering

Easy operated thumb switch

- > To control hydraulic functions
- > Clear operating units
- > Proportional solenoid offering a stable and comfort lowering action

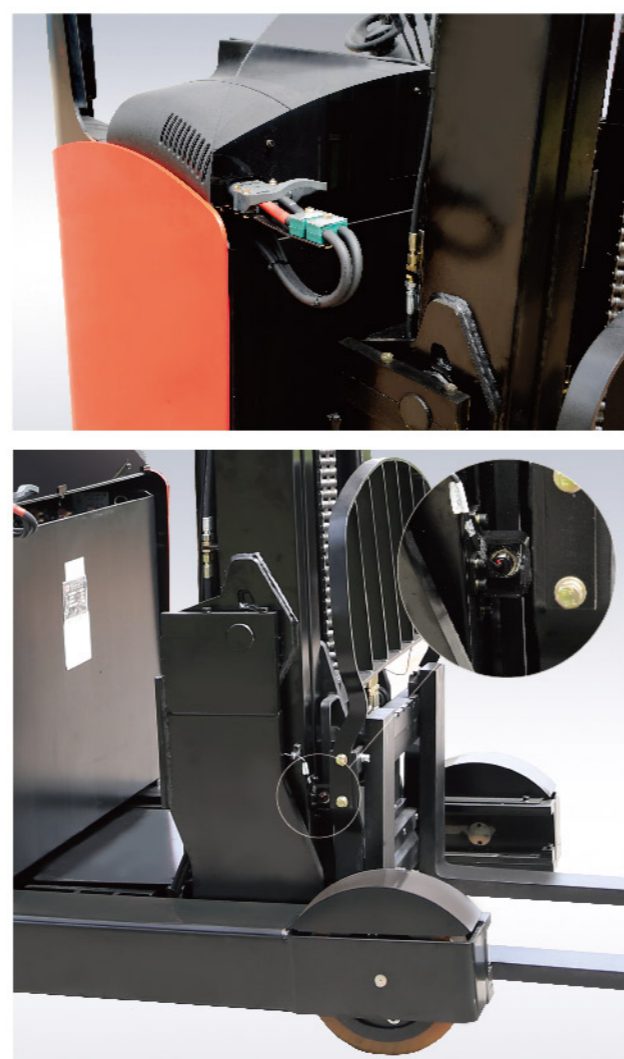

Displayer

- > High quality meter displaying important operating data
- > Display of traveling direction and drive wheel angle
- > Display of 180°/360° steering mode
- > Display of battery quantity and fault code
- > Travelling mode selection
- > Lifting lock indication
- > Hour meter
- > Labor hour display
- > Time
- > Fork height display (optional)

Wide view mast

- > Good view when loaded
- > Integral sideshifter
- > Mast vertical, fork tilt
- > High residual load capacity at high lift height
- > Lift height range:4600-12500mm
- > Buffering during lifting and lowering
- > Buffering on lifting and lowering limit
- > Buffering when cylinder moving forward

Comfort cab

- > Comfort cab offering driver good working environment and easy operation
- > Easy reach to important operation
- > Adjustable seat (seat position /backrest angle)

Overhead guard

- > Fence on top of the overhead guard offering driver wide view
- > Beveled view angle design with front ring beam meeting humanized requirements