

# CPD06-970

## 0.6 Ton Electric Stacker

Lifting Height: 1400-3300mm

### Load Curve



### Advantages

#### Configuration and Performance

- Short wheelbase and more flexible.
- Electronic power steering system, light and low noise.
- Two-way magnetic valve, three drop speed mode.
- AC Driving system, No carbon brush, Free maintenance.
- Electromagnetic, regenerative braking system.
- Automatic lifting limit, proximity switch, long life.

#### Safety

- Curve automatic deceleration devices, more safe.
- Vehicle decelerates automatically at higher position.
- Stepless speed control system, safe and quiet.
- Controller with Multiple automatic protection.
- Emergency reversing device/Emergency brake switch.



**AC | EPS**

**Down mode at 3 speeds**

**Steering automatic deceleration**

**Mini counter-balanced electric stacker**

Type	Lift height (mm)	Mast type	Outside width between legs (mm)	Inside width between legs (mm)
CPD06-970	1400/2000/2500/3000/3300	Standard 2-STAGE	200-660	0-460

Feature		
Model		CPD06
Configuration No.		970
Type		Counterbalanced
Mast type		Standard 2-Stage
Load capacity	kg	600
Load center	mm	500
Wheel base	mm	794
Operating type		Walkie/Stand On
Wheels		
Wheels type		PU
Wheel quantity Driving wheel/Balance wheel/Bearing wheel		1/0/2
Dimension		
Standard lift height	mm	1400/2000/2500/3000/3300
Max.extend height	mm	2400/3000/3500/4000/4300
Mast lowered height	mm	1230/1580/1780/2030/2130
Lowered fork height	mm	55
Fork size(length/width/thickness)	mm	1070/100/40
Overall length	mm	2240/2660
Overall width	mm	1015
Outside width between forks	mm	200-660
Inside width between forks	mm	0-460
Min.Turning radius	mm	971/1436
Min.Aisle width for pallets 800×1200	mm	2346/2822
Min.Aisle width for pallets 1000×1200	mm	2379/2844
MIn.ground clearance	mm	80
Performance		
Travel speed,laden/unladen	km/h	5/5.5
Lift speed,laden/unladen	mm/s	130/230
Lowering speed,laden/unladen	mm/s	130/230
Gradeability,laden/unladen	%	5/7
Electrical configuration		
Drive motor/Lift motor/Steering motor	kW	AC1.5/DC3/DC0.15
Battery voltage	V	24
Battery capacity	Ah	270
Brake		Electromagnetic/Regenerative
Controller		ZAPI (Options CURTIS)
Weight		
Battery weight	kg	247
Service weight with battery	kg	1561

\* Details of specifications and equipment are based on information available at time of printing and may change without notice.

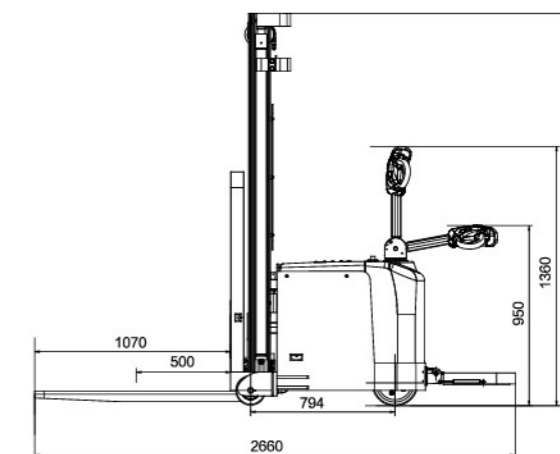
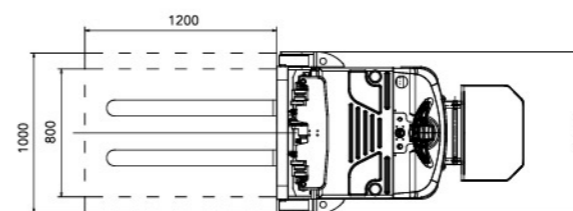

### ANHUI HELI CO., LTD.

ADD: NO.668 Fangxing Street,Economical Development Zone,Hefei,P.R.China  
 TEL : (86 551)63639068 (America) 63639258 (Europe) 63639358 (Asia)  
 63662105 (Africa & Middle East) 63639530 (Key Accounts division)  
 63662105 (Wheel loader)  
 FAX : (86 551)63639966  
 WEBSITE : <http://www.heliforklift.net>  
 Email : heli@helichina.net

AUTHORIZED DEALER